

LHS² – LINEAR ARM FIXTURES

Whether it's a small assembly group or mini series, a prototype or limited quantity production run – the more specialised and focussed your inspection and testing operations are, the more individuality the relevant hardware needs to offer. The universally applicable LHS² linear arm fixture from ATX is ideal for this purpose, because it adapts itself seamlessly to your specific application. In addition it enables you to implement your testing with simplicity and precision, but also at low cost.

As simple as it is efficient: our high-capacity mechanical testing concept.

Whatever individual parameters are your specific focus in inspecting and testing your assembly groups, as a leading technological and innovative supplier of high-quality mechanical test fixtures ATX is sure to have just the right solution for your specific requirements.

As your technical partners we support you with a wide range of benefits. Our fixtures are top quality, high capacity, easy to operate and low weight. You can rely on them to fulfil all your company's individual requirements. Economically beneficial

and ergonomically outstanding. In standard configurations or individually designed for your specific test environment - whatever suits you best!

A high-powered performance at all times

The ATX experts dedicate their entire know-how to smoothing the way to the optimum solution for you. We provide you with all-round consulting and recommend exactly the right solution, perfectly adapted to your test environment.

And if adaptation to new technical specifications is required later, you can rely on our support at all times.

MECHANICAL FIXTURES

LHS² – linear arm fixtures

H I G H L I G H T S

- Ideal for high-precision tasks
- Individually adaptable
- Effortless operation
- For two-sided operation
- Available in 5 sizes

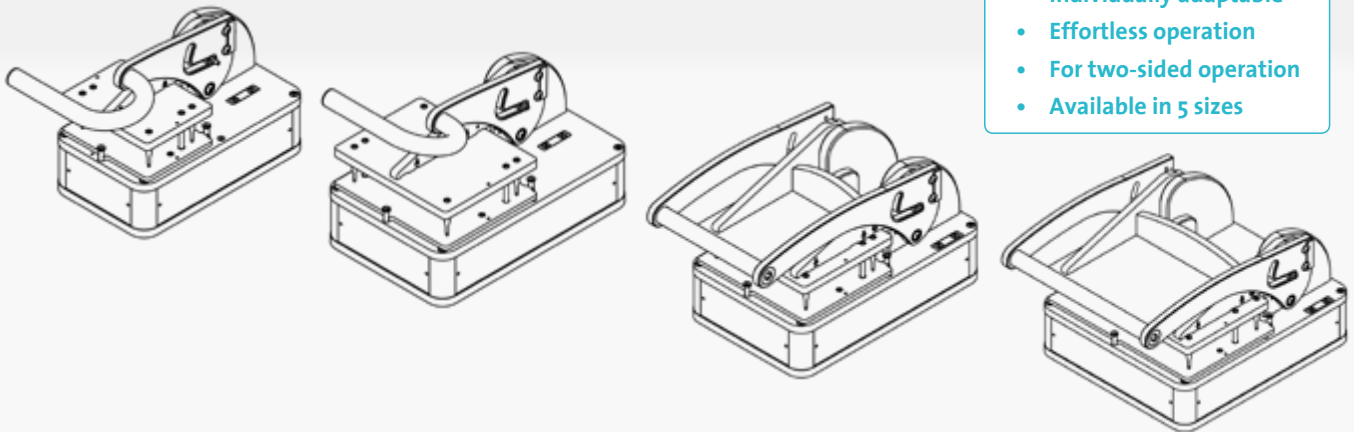

Contacting made simple by a compact and efficient unit

Regardless of whether your company's inspection and testing work deals with experimental series, localised and limited analyses or even laboratory operations: whether you wish to implement the requirements of your programming test stations even more efficiently with a mechanical fixture; or whether you wish to equip your functional test stations innovatively for future tasks and open up new dimensions for your function tests. In the LHS² linear arm fixture from ATX you have the ideal unit for all these purposes, with a wide range of impressive features. Our LHS² is even suited for flash programming tasks, if this is an option you need. And if your specific application requires this, the unit also offers two-sided operation.

The LHS² from ATX is not only small, extremely compact and totally uncomplicated in its operation – it also enables you to master all your testing operations quickly and economically. And because you will be adding a „Made in Germany“ mechanical fixture to your testing environment, you can be sure of premium quality, outstanding technical features and a long product life.

But that's not all. Because our linear arm fixture represents an entry to mechanical inspection and testing which has been tried and tested over many years, we can offer you optimum technical capacity for comparatively little money.

- Available ex-stock as a standard kit at any time, if you wish to extend the unit yourself,
- Or as an individually designed special model which is made to measure for your specific requirements.

Simply let us know what your test-specific wishes are and we will design a tailor-made solution which will also offer you the full range of modification and adaptation options later, too.

The high-capacity LHS² from ATX is available in four sizes. It represents precise results because it supports your testing experts with linear lift. In application the lever is lowered vertically onto the test probes, avoiding any bending of the probes and providing you with reliable test results.

In 5 compact standard sizes*

Order number	Designation	Moving plate	Contact pressure
100707	LHS ² -A	85 x 85	100N
100331	LHS ² -B	125 x 125	100N
100828	LHS ² -D	125 x 125	200N
100961	LHS ² -F	200 x 130	200N
100329	LHS ² WG-F	200 x 130	200N
100330	LHS ² WK-F	200 x 130	200N

pneumatic locking LHS²

Order number	Designation
100335	LHS ² pneumatic locking with lift magnet
100334	LHS ² pneumatic locking with cylinder

* Each supplied with 20 30 mm pushfingers, 4 35 mm holding-down devices and 20 UUT supports.

AVAILABLE HOUSING OPTIONS

If required we adapt the technical design exactly to your requirements

Housing with back panel (connectors can be fitted as required)

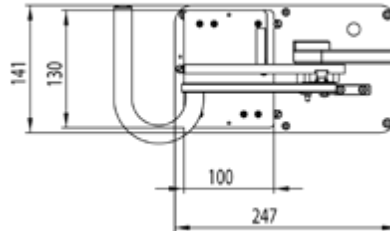
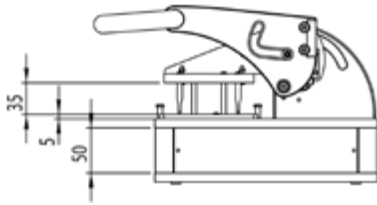

100707

Standard housing for LHS²-A

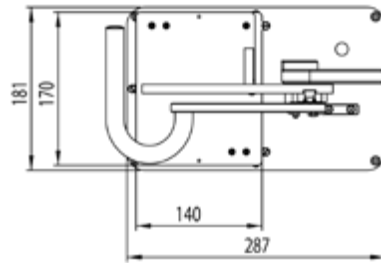
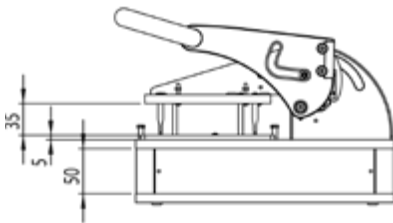

100331

Standard housing for LHS²-B

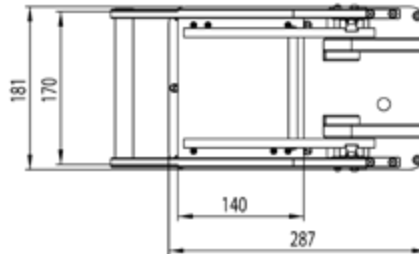
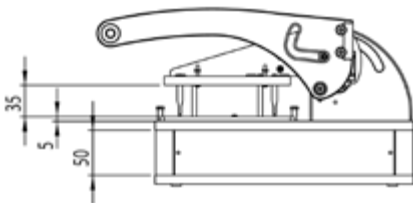

100828

Standard housing for LHS²-D

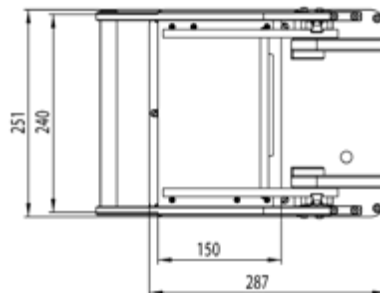
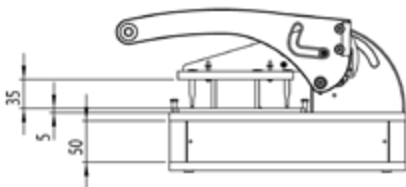

100961

Standard housing for LHS²-F

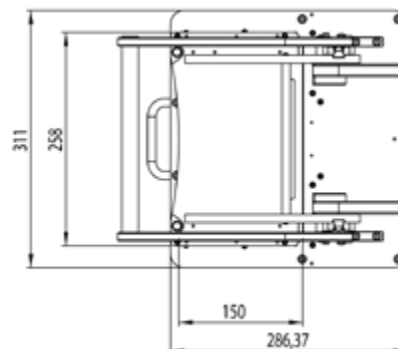
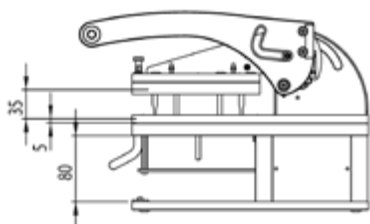

100329 **100330**

Standard housing for LHS²W-F

Contact us

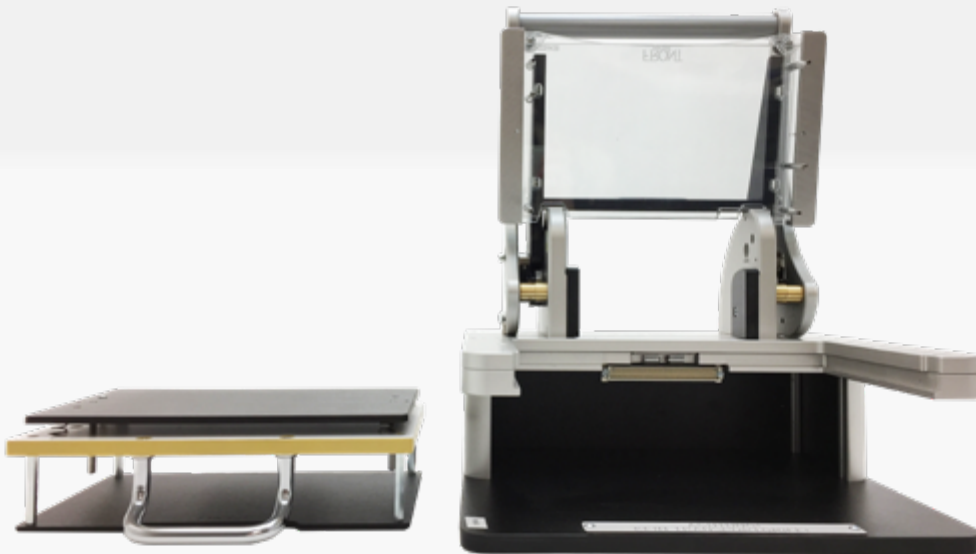

Would you like to find out more about us or get in touch with the appropriate contact person? You'll find the direct line on our website - together with your personal sales expert:

www.atx-hardware.de ▶ [Contact](#) ▶ [Contact partner](#)

We are committed to finding the optimal technical solution for you. Why not put us to the test!



ATX Hardware GmbH West
Subsidiary of ATX Hardware GmbH

Pürgen branch
Am Kornfeld 8
86932 Pürgen, Deutschland/Germany

Phone: +49 81 96 / 93 04 - 0
Telefax: +49 81 96 / 93 04 - 19

Email: projekte@atx-hardware.de
Web: www.atx-hardware.de

Weil branch
Carl-Zeiss-Straße 5/1
71093 Weil im Schönbuch, Deutschland/Germany

Phone: +49 81 96 / 93 04 - 345 or 349
Telefax: +49 81 96 / 93 04 - 359

Email: projekte@atx-hardware.de
Web: www.atx-hardware.de